

User Manual



Warning

Please follow safety instructions in this booklet to avoid seriously injuries or even death.

Important

Please read this manual carefully and follow the instructions. Only authorized people can use this Dryer. For any question please contact REKTÖR MAKİNA.

Index

Foreword	: 1
Warning signs	: 2
Safety rules	: 3
Operating Instructions	: 4
Pre-Operation Inspection	: 5
Install and transport	: 6
Usage and Storage	: 7
Working Life Time and Noice Declaration	: 8
Technical Specifications	: 9
Maintenance Programme	: 10
Troubleshooting	: 11
Drying Room	: 12
Fan and Heat Isolation	: 14
Cables	: 15
Cable Connections for additonal Fans	: 16
Removable Parts	: 17-19
Technical Drawings	: 20-25
Control Panel (Time Relay)	: 26
Control Panel (Dehumidifier)	: 27-28
Contorl Panel (Dryer)	: 29-30
Electric Sheme	: 31

Warning Signs



Please avoid contact with liquids



Do not run the Dryer with peeled cables



Avoid Cable Jams

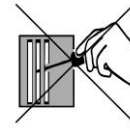

Do not approach with sharp and spike materials



For Repair and Maintenance Call Technical Service



Safety Rules



Warning

Please follow safety instructions in this booklet to avoid seriously injuries or even death. Please read safety instructions this manual carefully before operating the Dryer. Avoid dangerous situations. Before operating the Dryer, always make safety inspections. Always inspect the working area of the Dryer (electrical connection and cable). Use the Dryer only for its work purpose. Please follow all instructions in the user manual as well as all signs on the Dryer. Please study the Dryer for safety operation.

Electrical Shock Hazard

This machine has a ground connection to the power outlet. Always connect the grounding cable and check your grounding line. If the grounding cable is not connected and if there is electricity leakage, machine gives electric current to outside. This Dryer has no electric isolation and can not protect against electrical contact. Please keep away from the Dryer in case of electrical contact. Otherwise, there will be an electrical shock and seriously injures and even death.

Hazards caused by failures of the Dryer

Please do not operate a defective Dryer.

Wrong operating hazard: Please do not leave the Dryer unattended. Dryer operated by unauthorized person can cause seriously injures or even death.

Usage Instructions



Basic Items

The usage instruction section, includes all operating instructions. It is the responsibility of the operator to follow the safety instructions.

It is not safe to use the Dryer for purposes other than its purpose mentioned herein. If the Dryer is used by more than one operator, each operator has to follow all instructions; before operating the Dryer, always make safety necessary inspections. Always make a function test. Always inspect the working area of the Dryer.

Always check these points before starting: electrical connection point of machine, fuse, connection point of cables in electrical panel, attachments of cables, socket. If there is a loose connection, these things warm up and can cause fire. If there is a loosening or heating, it must be repaired by authorized persons.

Electrical cables should not be added in the drying room. There should be no fuse and socket in drying room.

Usage Instructions

The Dryer is designed for heating, dehumidifier and drying a isolated closed area with a volume of 100m³.

Besides, the Dryer can be used as a dehumidifier for 2000m³ . (Room without isolation).

Pre Usage Inspection Process



Basic Item

A Pre-Usage Inspection, is a visual control made by the operator with control and safety equipment (Electric insulated hand tools - Screwdriver, Pliers, Control pen, Glove-) before operating the Dryer. Please check each item the list next page. In case of any changes comparing to factory defaults and / or defect caused by producer, make sure that the Dryer will not be operated.

It is clearly mentioned in this user manual, that the repairment of the Dryer should be made only by qualified technicians. After the repairment, the operator should make the routine pre-operation inspections.

Pre-Usage Inspection Process

Make sure that the whole user manual is always readable and fully available. Make sure that all security tags are in its place as shown in the tag section.

Please check following items for damage, improper installation or missing parts and check if anything is changed.

1. Make sure that all removable parts are in its place
2. Make sure that the Power Cord is connected to grounded fuse
3. Open the air output vent with the lever. Leave at least 50cm space for the suction input and blow output.

4. Fix the dryer on a plain ground.

Install and Transport



Install



Fix the Dryer on a plain ground. To fix the Dryer on a plain ground, lock the two frontwheels.

After all security inspections, connect the power cord of machine to a 380V grounded electric fuse. Switch the Dryer on as shown in the image.



Transport

Make security precaution before transporting the Dryer. While moving/transporting the Dryer please consider that its weight is 150kg. The transportation is dividen into three main processes.



1. Moving/Transporting on a plain ground: After unlocking the wheels you can move the Dryer via transportation handle.



2. Moving/Transporting on a uneven ground: Make security precaution and lift the Dryer on its big wheels move the Dryer.



3. Moving/Transporting by by carrying: This macine can be carried by two persons. Carry the Dryer as shown in the Picture. Lift the macine on its big wheels and and The second person can lift the Dryer up via the small front wheels.



4. Long Distance Transportation: For Long distance Moving/Transportation put the Dryer in its crate. To avoid any damage during the transportaion fix the Dryer in the crate. The total weight (the Dryer itself and the crate) is 235kg.

Usage and storage



R 407c What to consider

RM 55000 dryer heat pump works with compressed freon gas (Chlorofluorocarbon compound) in a closed circuit on the heatexchanger. Damagin the heatexchangers during usage or storage may cause leaking freon gas (Chlorofluorocarbon compound). When hitting the heatexchanger with an sharp metal may cause compressed freon gas (Chlorofluorocarbon compound) leak.

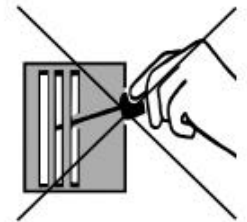

R 407c: It is liquid gas and compressed. In case of contact with flame or extremely hot metal surfaces can be released toxic and corrosive products. The steam of it is heavier than oxygene and reduces oxygene in the air. Inhaling freon gas can cause heart irregularities, consciousness loss. Contact with eye and skin can

cause frostbite.

First aid for R 407 c Freon Gas Injuries

When contact with eyes, wash it out with plenty of water. If the freon victiom can not breath, provide the patient with artificial respiration. If spilled or leaked outdoor; hold it against the wind. If spilled or leaked indoor; empty the place and deploy gas through a ground level ventilation. Do not smoke and do not start any internal-combustion engine. Keep away flames and heatet elements.

Working Life Time and Noise Declaration



Working Life

1. Heat Pump 32.000 hours
2. Fan Engine 17.280 hours

When working life has of a spare part is over, it should be replaced with a new one in order to make the Dryer work again.

Note: Sparepart replacement should only be done by an authorized technician.

Noise Level

V 4.4 – 71-89 dB

V 6.1 – 71-89 dB

V 9.0 – 75-92 dB

Technical Specifications



It is the policy of Rektör Makine to improve its products continuously. Rektör Makine has the right to change the product specifications without prior notice.

Rm 55.000	V 4.4	V 6.1	V 9.0
Dimension (cm)	86-93-136 cm	86-93-136 cm	86-93-196 cm
Weight	180 Kg	190 Kg	270 kg
Energy Consumption	6.2 Kw/h	9.2 Kw/h	14.2 Kw/h
Current Draw	10.1 Ampere	14 Ampere	22 Ampere
Initial Current	55 Ampere	65 Ampere	96 Ampere
Power Supply	342-462-V-3-50 Hz 414-506-V-3-60 Hz	342-462-V-3-50 Hz 414-506-V-3-60 Hz	342-462-V-3-50 Hz 414-506-V-3-60 Hz
Effective area (heated)	100 m ³	100 m ³	100 m ³
Effective area (non-heated)	2000 m ³	2000 m ³	2000 m ³
Dry air output	% 18 rh	% 18 rh	% 18 rh
Air Flow			
Dry Air Flow	2800 m ³ /h	2800 m ³ /h	2800 m ³ /h
Warm Air Flow	4000 m ³ /h	4000 m ³ /h	8000 m ³ /h
Total Air Flow	6800 m ³ /h	6800 m ³ /h	10800 m ³ /h
Operating Temperature Range			
Max Heating Capacity	45 °C	45 °C	45 °C
Max Working Temperature	50 °C	50 °C	50 °C
Min Working Temp.	5 °C	5 °C	5 °C
Heating Capacity	6.400 kcal/h	12.000 kcal/h	25.000 kcal/h
Operating Humidity Range			
Adjustable humidity range	%0 / %100	%0 / %100	%0 / %100
Max. Operating Humidity	%100	%100	%100
Min. Operating Humidity	%0	%0	%0
Dehumidifying Capacity	20 °C %60 - 216 lt/daily	20 °C %60 - 265 lt/daily	20 °C %60 - 320 lt/daily
Max. Dehumidifying Cap.	45 °C %60 - 480 lt/daily	45 °C %60 - 720 lt/daily	45 °C %60 - 1050 lt/daily

Maintenance Programme



Daily Maintenance

Machines with air filter, should be cleaned daily. The cleaning should be made with high pressure water or high pressure air.



Monthly Maintenance

Remove the air input filter and clean the aluminium surfaces with high pressure water or vacuum cleaner.



Annual Maintenance

The annual maintenance should be made by an authorized technician. The heat exchangers should be removed and cleaned. The machine is tested for gas and performance.

Note: The maintenance intervals may vary depending on the pollution rate.

“Beware of sharp parts while cleaning.”

“Wear Safety Gloves!”

Troubleshooting



Fault Detection : In case of a fault, check switch and the warning mechanisms in the Electric Panel. Shown in the images and explanations Detect the Fault.

1. The Fan Engines will be disable if the Fuse is switched off. To re-operate the Fan Engines switch the Fuse Switch to on.
2. Check the Heat-Pump Engine protection switch, if the switch is on the 0 position, the protection switch is switched off and the electrical cuircuit has been interrupted. To re-operate the Heat-Pump turn the switch to position 1.
3. The Contactor is used to transfer power.
4. If the Gren-Led On the MKS 01 is off, there is a electricity problem.
5. When the Heat-Pump Engine re-operates, first the “on led” lits and then the “out” led lits. When these leds are not lit, that means that a electrical fault has occured.
6. Will only engaged below certain temperatures and avoids the dryer to freeze.
7. In case of high current, the thermal switch cuts the circuit and provides protection and engages it self again.
8. Fan relay. When the fan relay is broken only machine’s fans will not work. The machine's internal motors rarely work (e.g; working- stop- working- stop ...). So that this part is broken. If this part is broken again after changing, the fans are faulty.

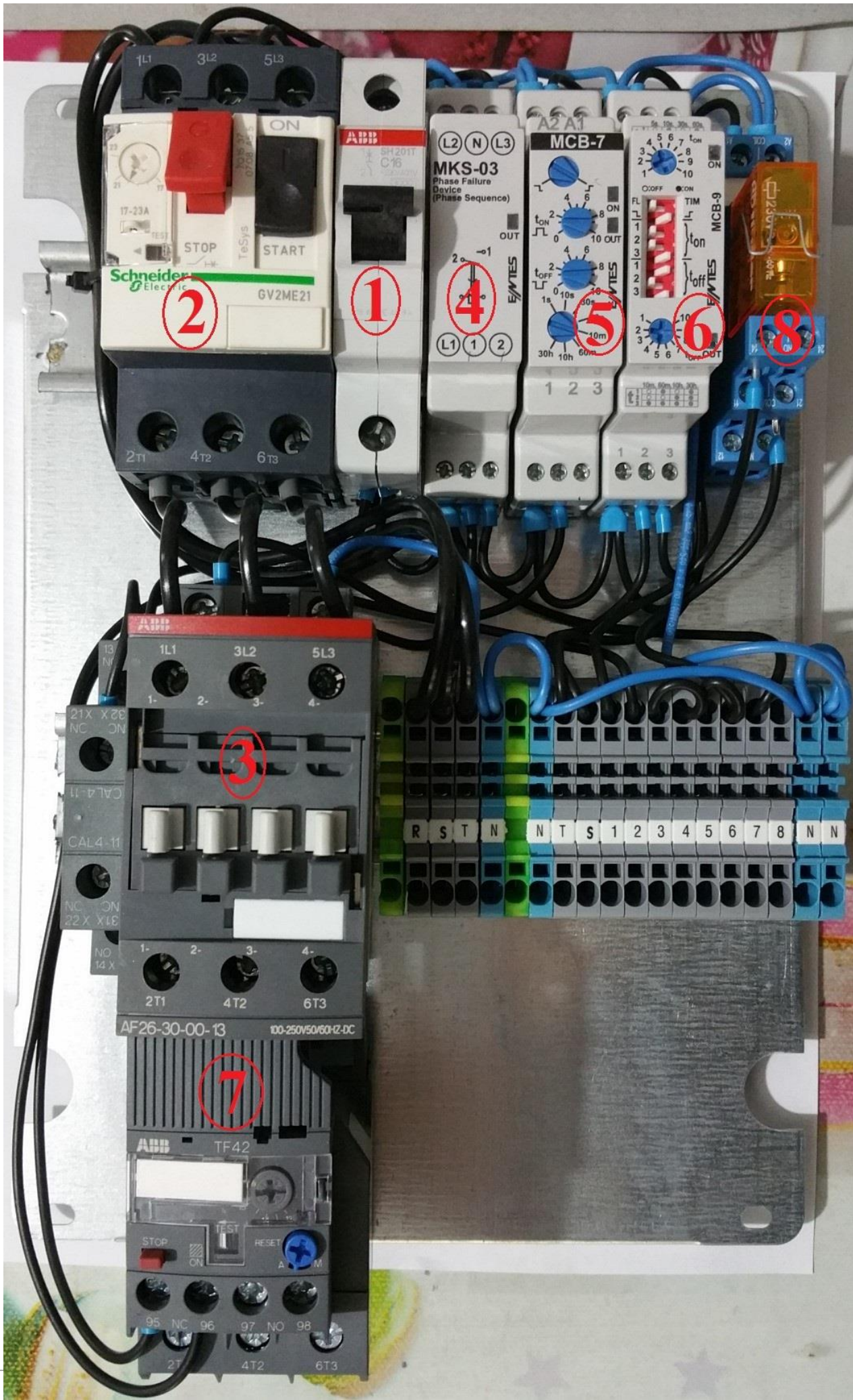

Drying Room

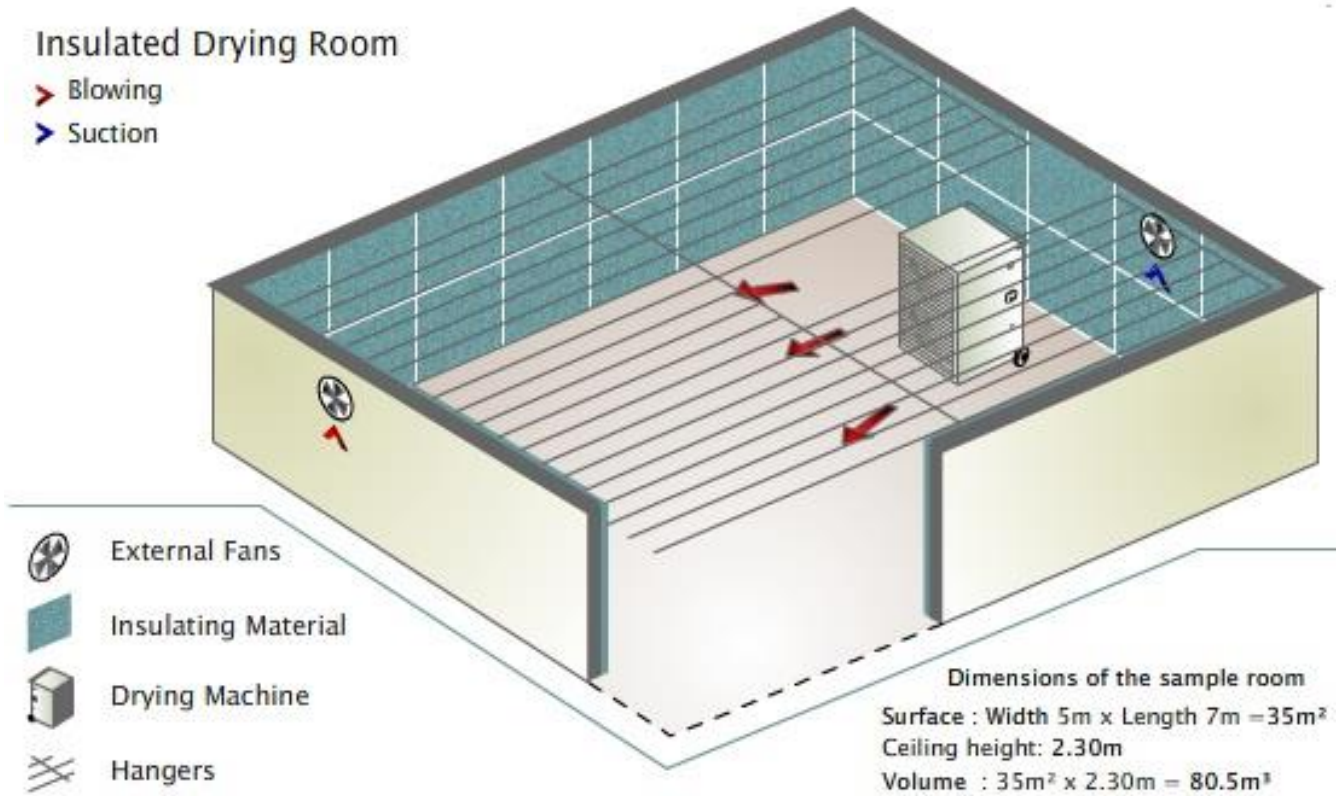

Drying Room

The Drying Room should not be bigger than 100m³. For Rooms with more than 100m³ a second dryer is required. The volume of the room depends on the ceiling height. The ceiling should not be higher than 2,5m.

For Example; A room with a ceiling height of 2,5m should be max. 40m². 40 x 2,5 = 100m³



Fan and Heat Isolation

External Fan (With Automatic Blinds)

2 Fans with automatic blinds and air sealing feature should be mounted like shown in the drawing. The Fans should be positioned diagonally. Fans are operating connected to the dryer. If required the Dryer activates the Fans. One Fan operates as air input fan and the other air output fan. The purpose is to balance the heat in the room.

External Fan (Heat Recovery)

The heat recovery fan should be mounted on the ceiling of the drying room like shown in the drawing.

It is positioned on the ceiling of the drying room at the right or left corner. There must be min. 50 cm clearance on the sides of the fan.. Fans are operating connected to the dryer. If required the Dryer activates the Fans. The moist air is blown out by the fan. The heat air in the room returns. And heat loss is stopped.



Isolation

When preparing a drying room, the inside of the room should be isolated.



Drying Process takes more time in a Room without isolation.
Less Heat-Loss equals short Drying Process.

Compressed Styrafoam

The insulation is a 40 density 3 cm compressed foam alloy.
It is used for hot, cold and sound insulation.

Compressed Styrafoam is mainly used for outdoor cold and heat isolations.

To avoid heat-loss in the drying room all surfaces (floor, walls and ceiling) of the drying room should be covered with compressed styrafoam. Alternatively to avoid possible oppression on the floor, materials like sandwich panels can be used.

Cables

 -Ground

N - Neutral

L1 - 1. Phase

L2 - 2. Phase

L3 - 3. Phase

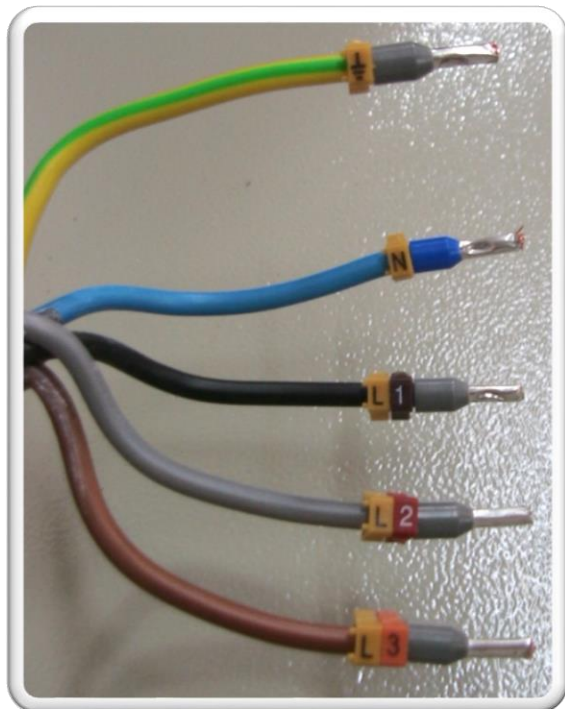

Fan Cables

N - Neutral

L1 - Phase

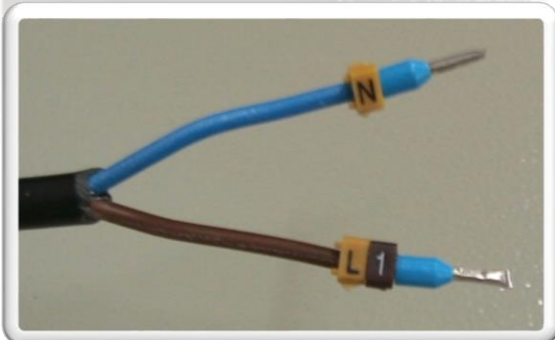

Cable Connections for additional Fans

Connecting cables

L1 - Brown cable

N4 - Blue cable

External Fan (With Automatic Blinds)



External Fan (Heat Recovery)

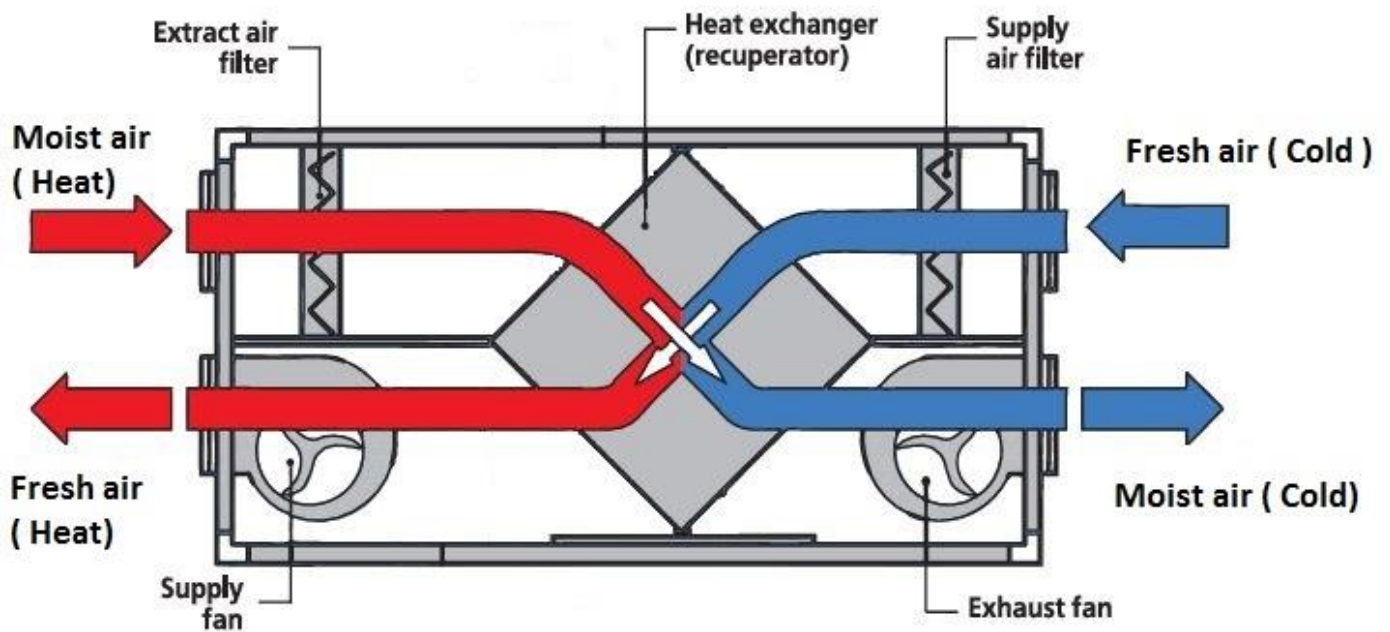

Removable Parts

During the maintenance of the Dryer, remove only the parts 3 and 9. All other parts should be removed by authorized technician. The order removing process is shown below. Do not operate the Dryer during the remove process. Disconnect electrical connection. Close the fuse.

Things to do when removing parts

Remove the screws the held the parts together. Remove the parts in the order shown below. To re attach the parts follow the order backwards. Wthen removing part nr.6 (Left Cover) water discharge hose and on of switch as well as the power cables should be removed. Please check the electric panel knowledge before removing cables.

- For V 4.4 ve V 6.1
- For V 9.0

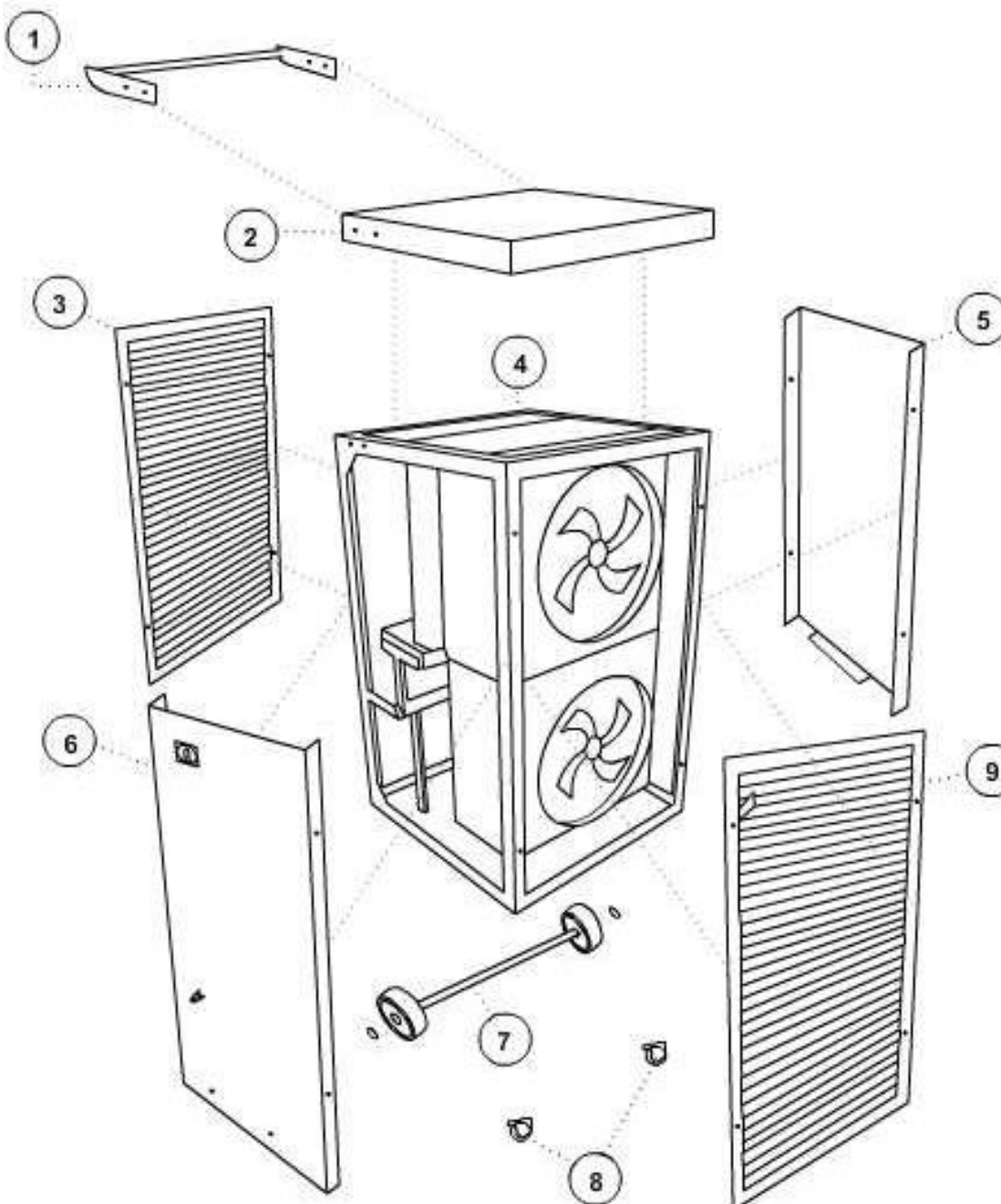

Part Names

- 1- Carrying handle
- 2- Top cover
- 3- Supply register
- 4- Main body
- 5- Right cover
- 6- Left cover
- 7- Big wheels
- 8- Small wheels
- 9- Exhaust register

Detach Order

- 3- Supply register
- 9- Exhaust register
- 1- Carrying handle
- 2- Top cover
- 7- Big wheels
- 5- Right cover
- 6- Left cover

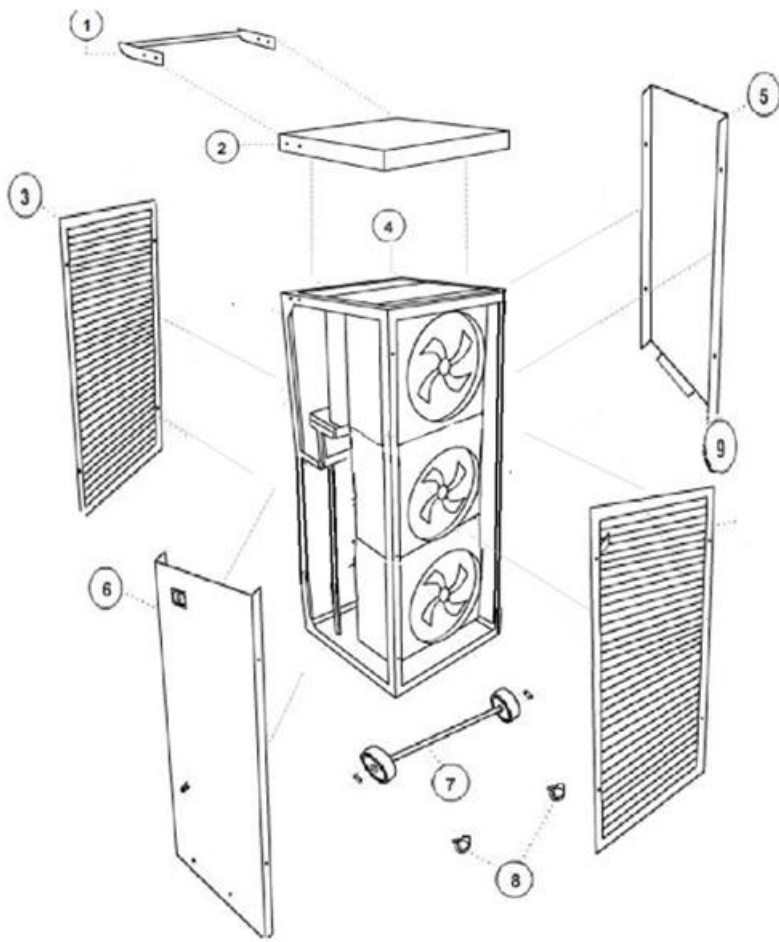

Part Names

- 1- Carrying handle
- 2- Top cover
- 3- Supply register
- 4- Main body
- 5- Right cover
- 6- Left cover
- 7- Big wheels
- 8- Small wheels
- 9- Exhaust register

Detach Order

- 3- Supply register
- 9- Exhaust register
- 1- Carrying handle
- 2- Top cover
- 7- Big wheels
- 5- Right cover
- 6- Left cover

AIR SEALING PARTS

- For V 4.4 and V 6.1

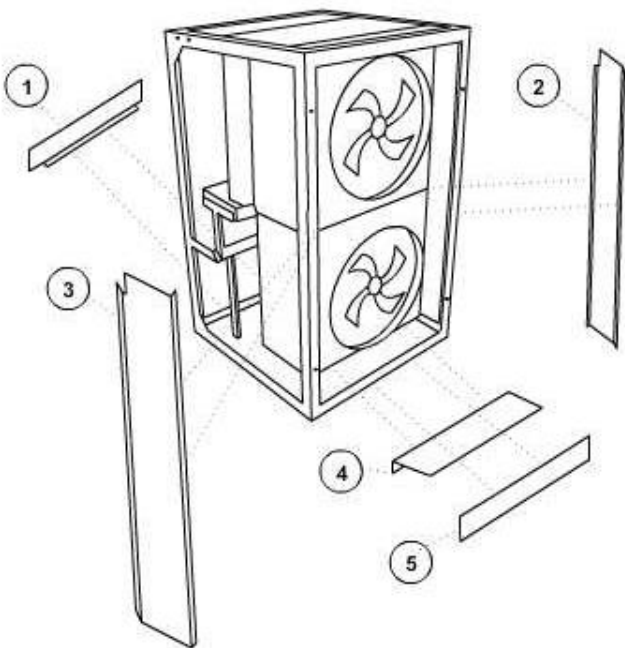

Part Names

- 1- Back coating
- 2- Right inner accent
- 3- Left inner accent
- 4- Bottom inner accent
- 5- Front coating

- For V 9.0

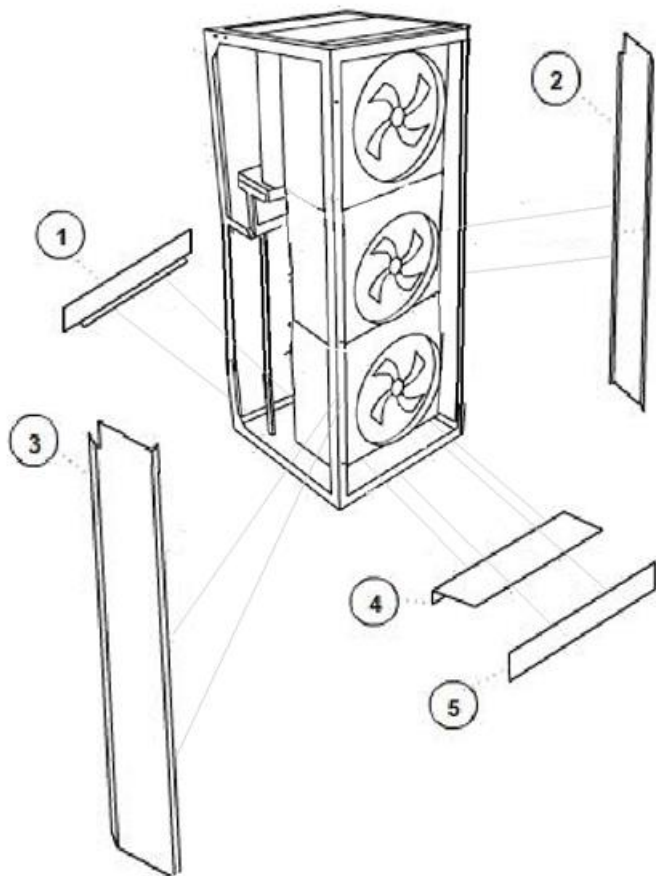

Part Names

- 1- Back coating
- 2- Right inner accent
- 3- Left inner accent
- 4- Bottom inner accent
- 5- Front coating

Technical Drawings

- V 4.4

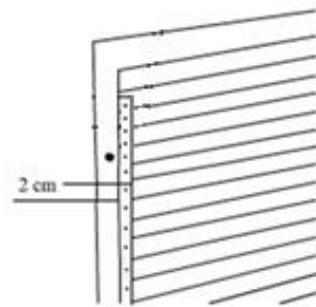
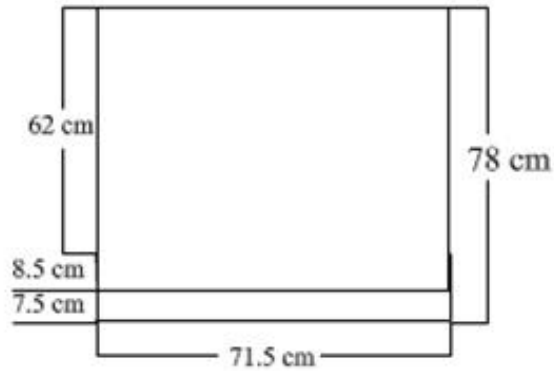
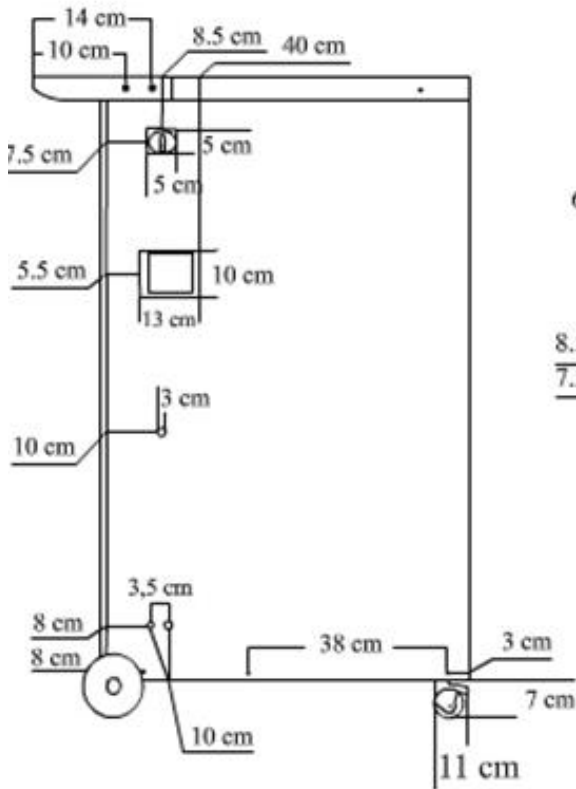
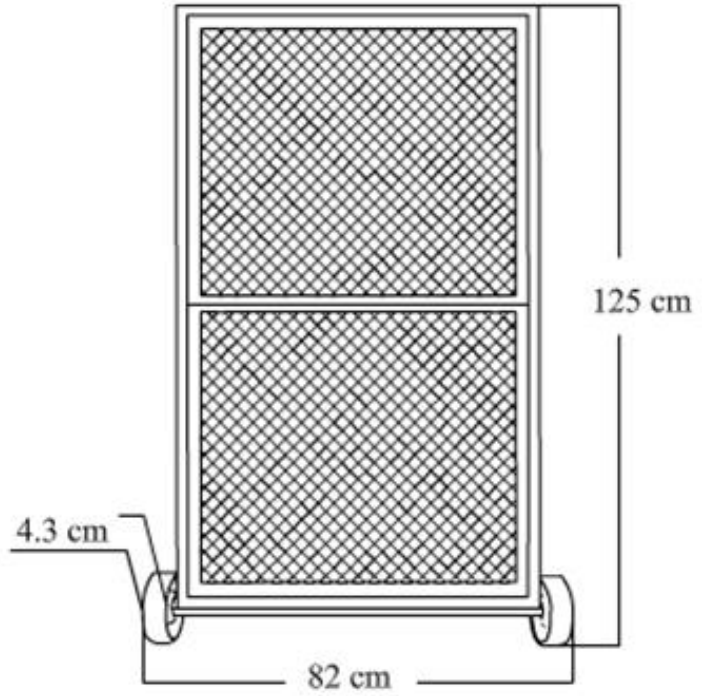
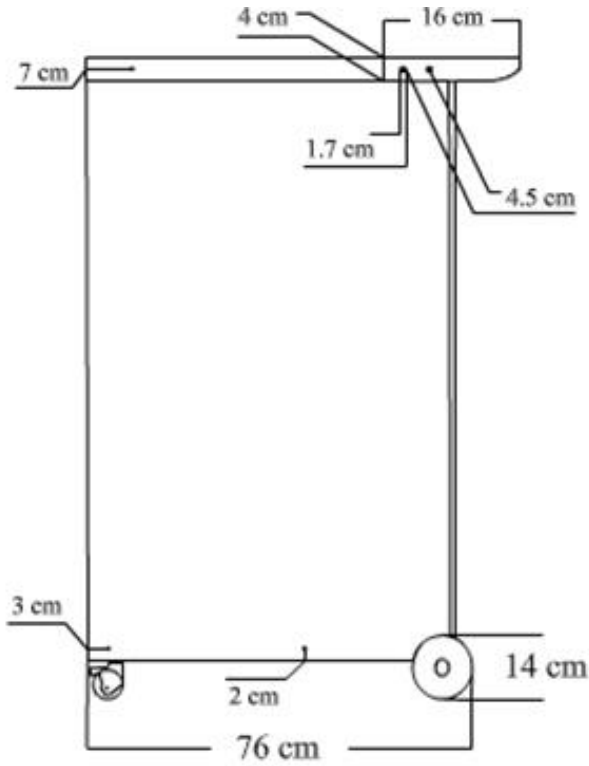

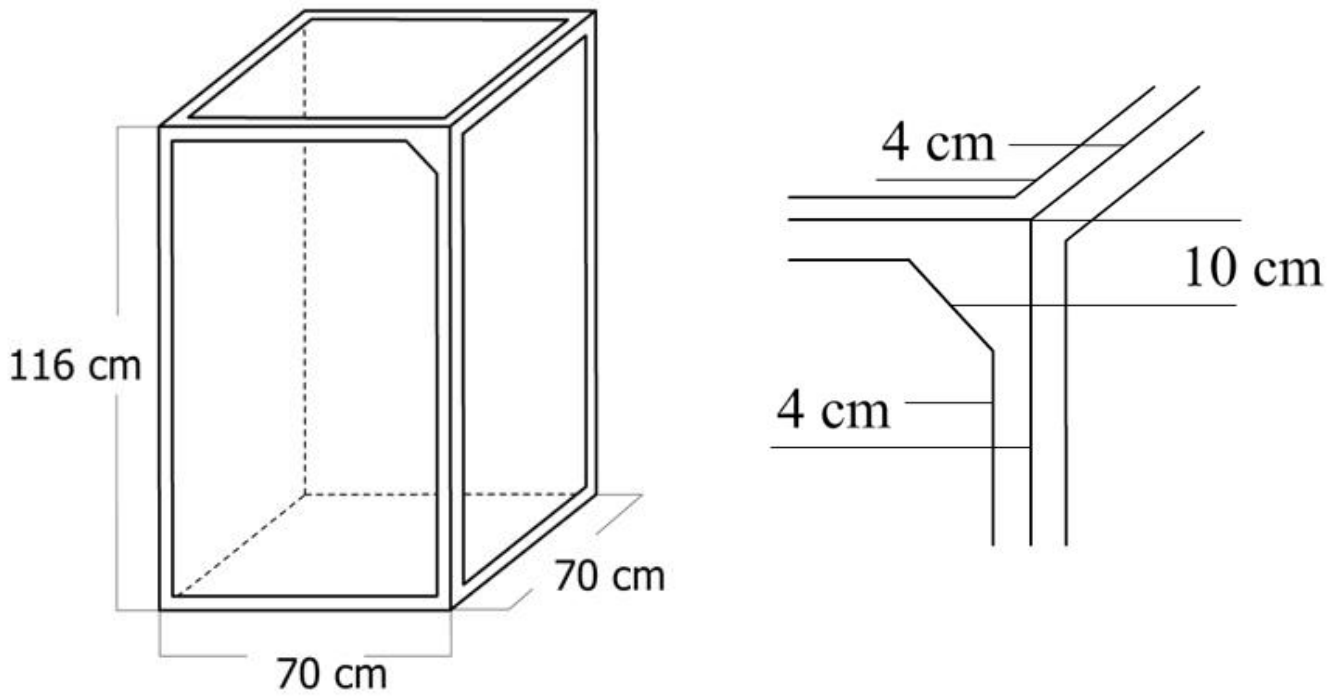

• V 6.1

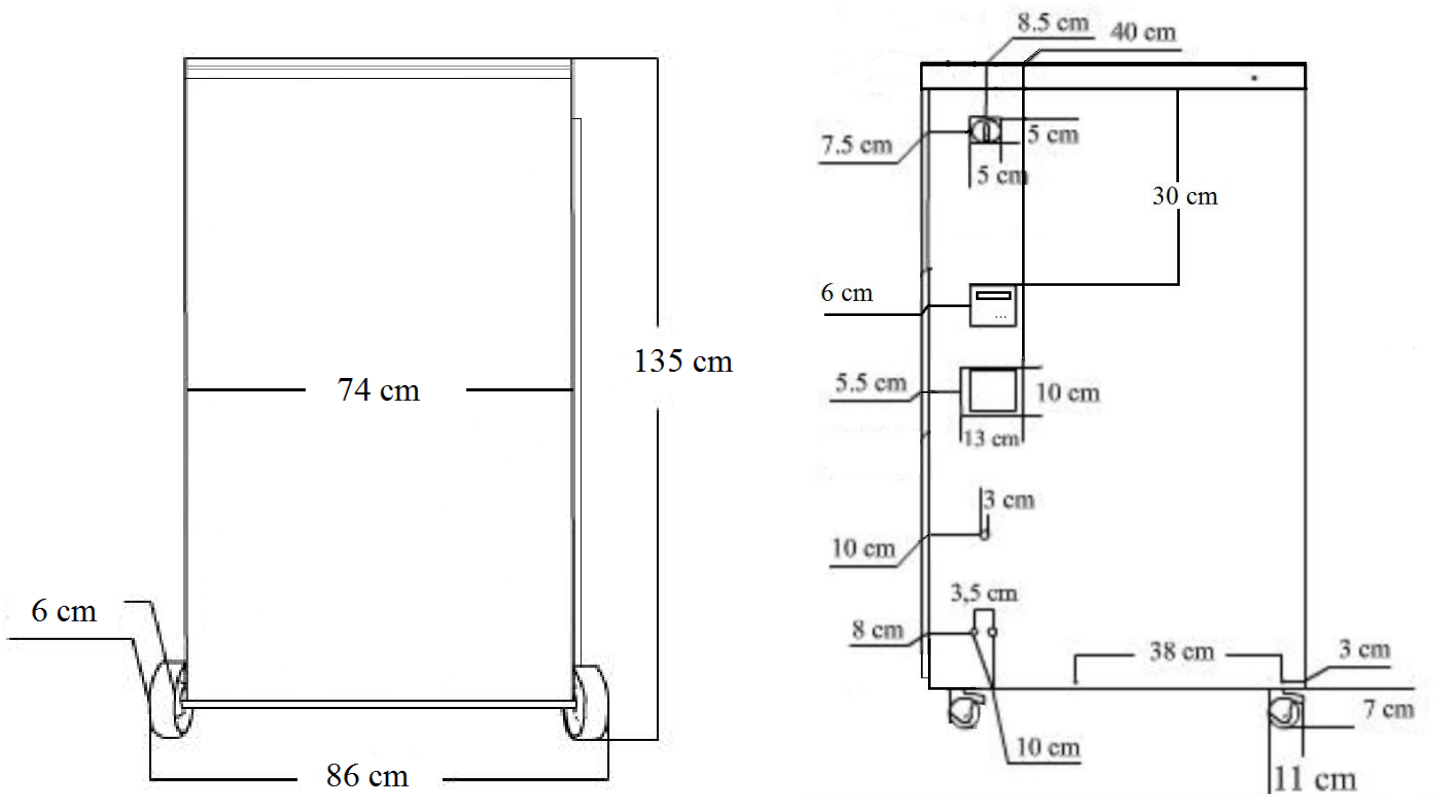

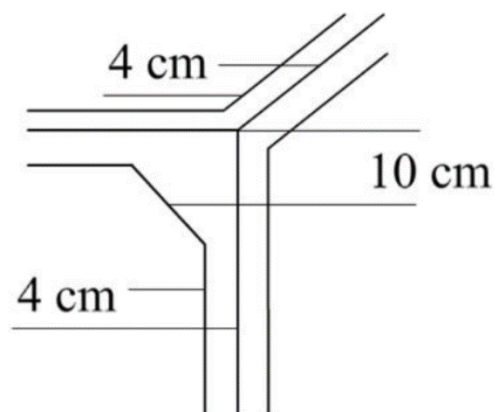
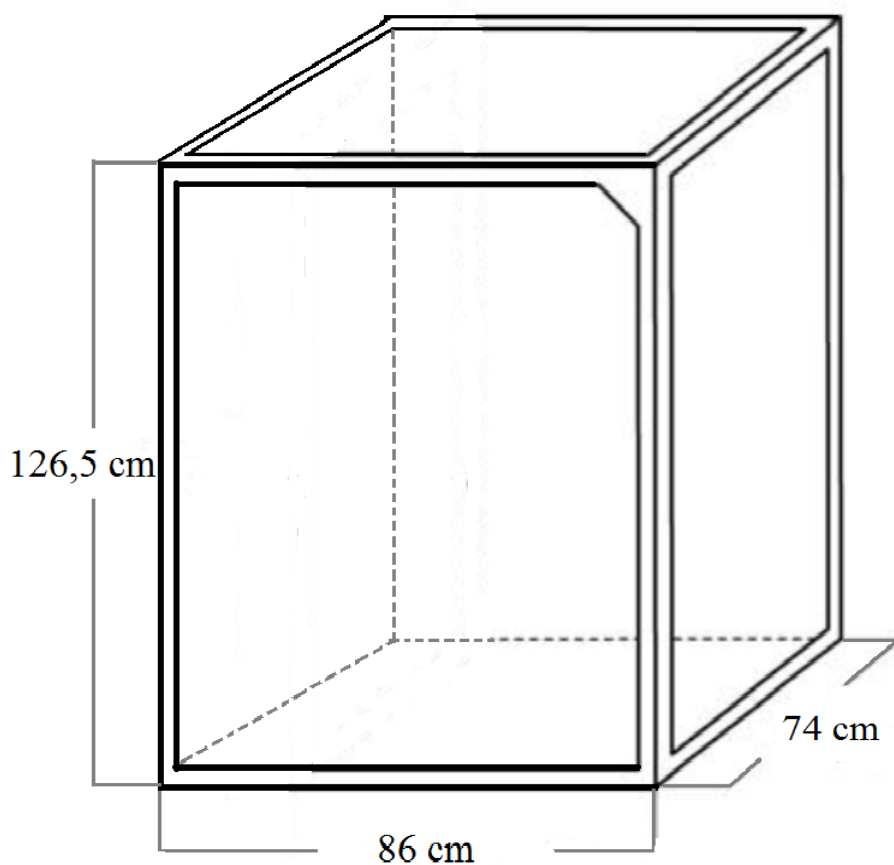
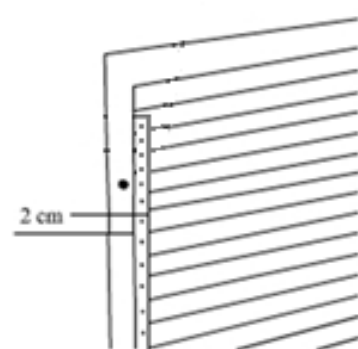
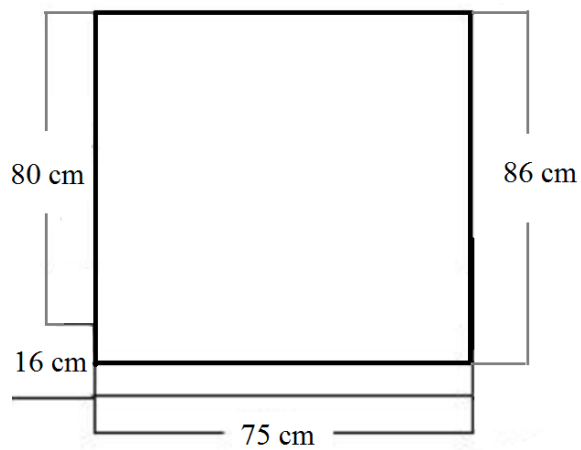
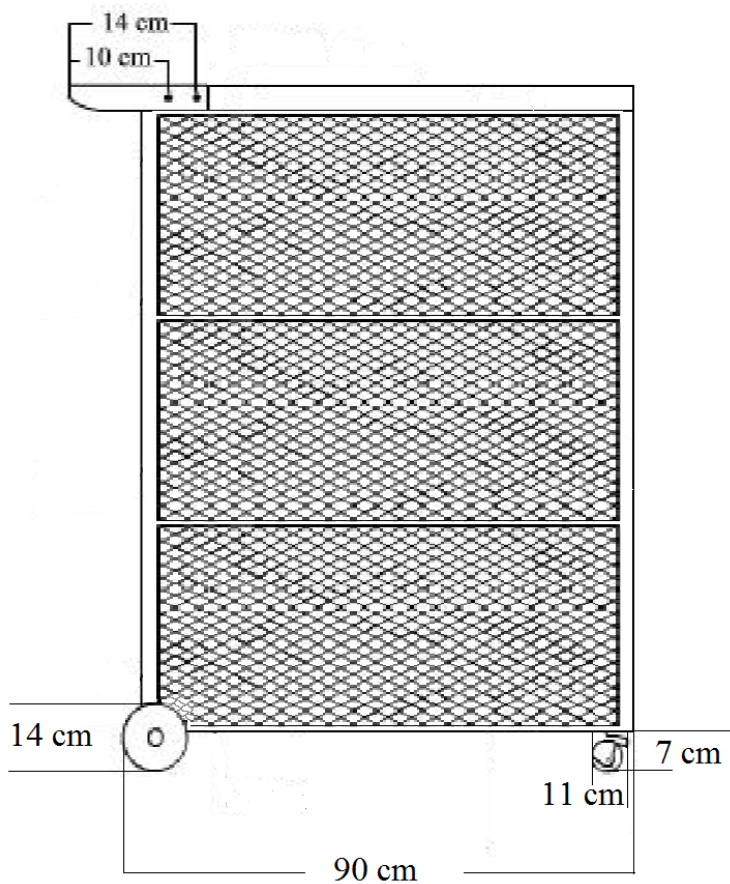

• V 9.0

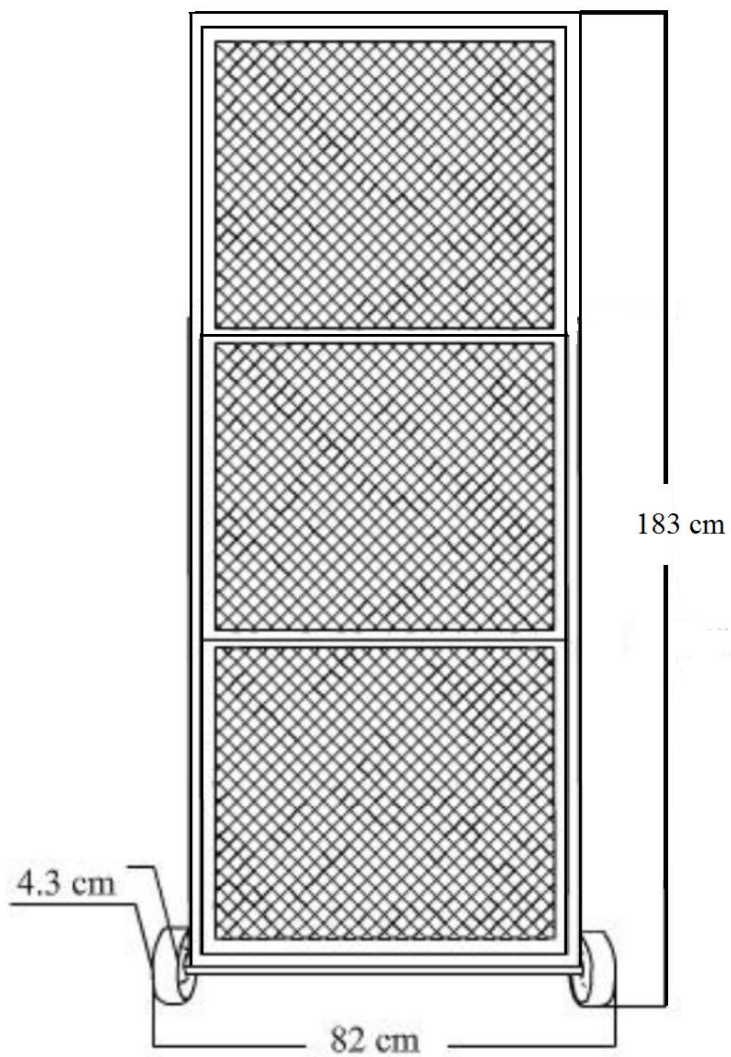
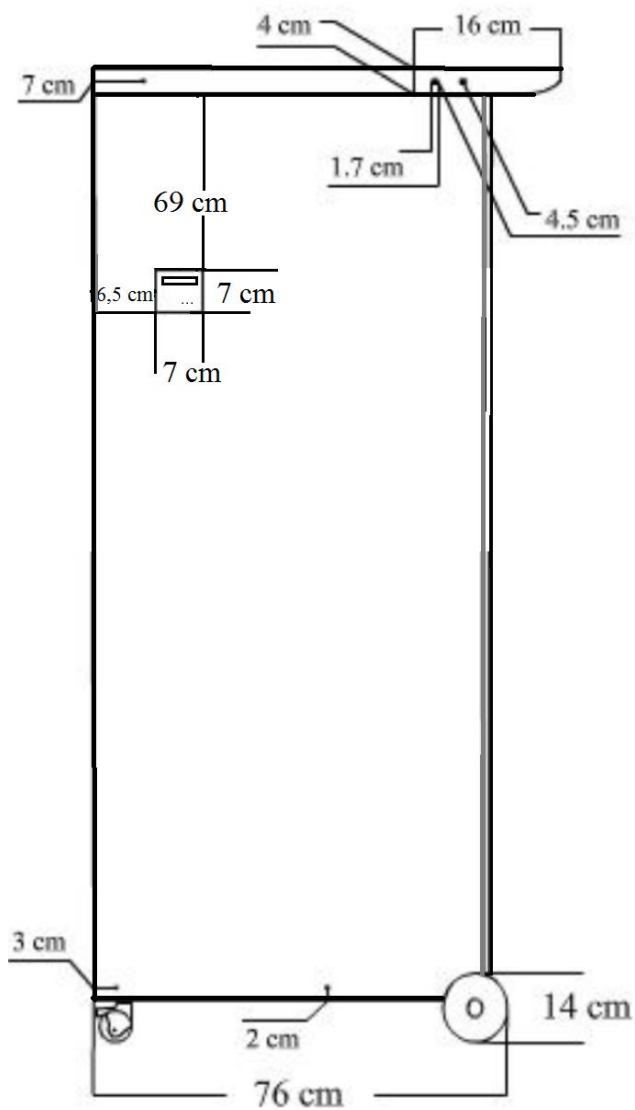

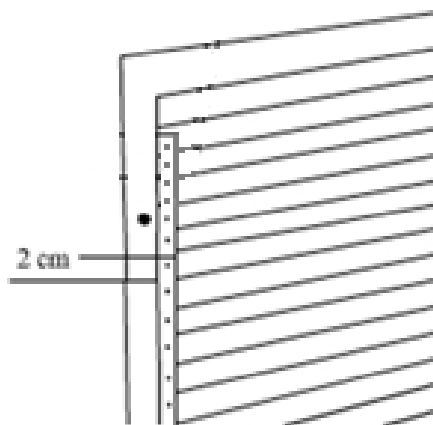
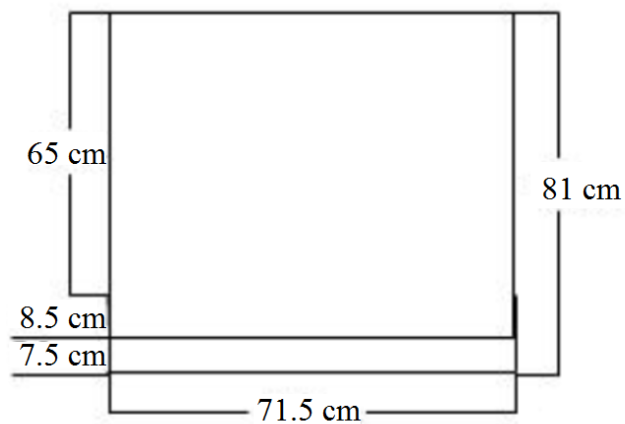
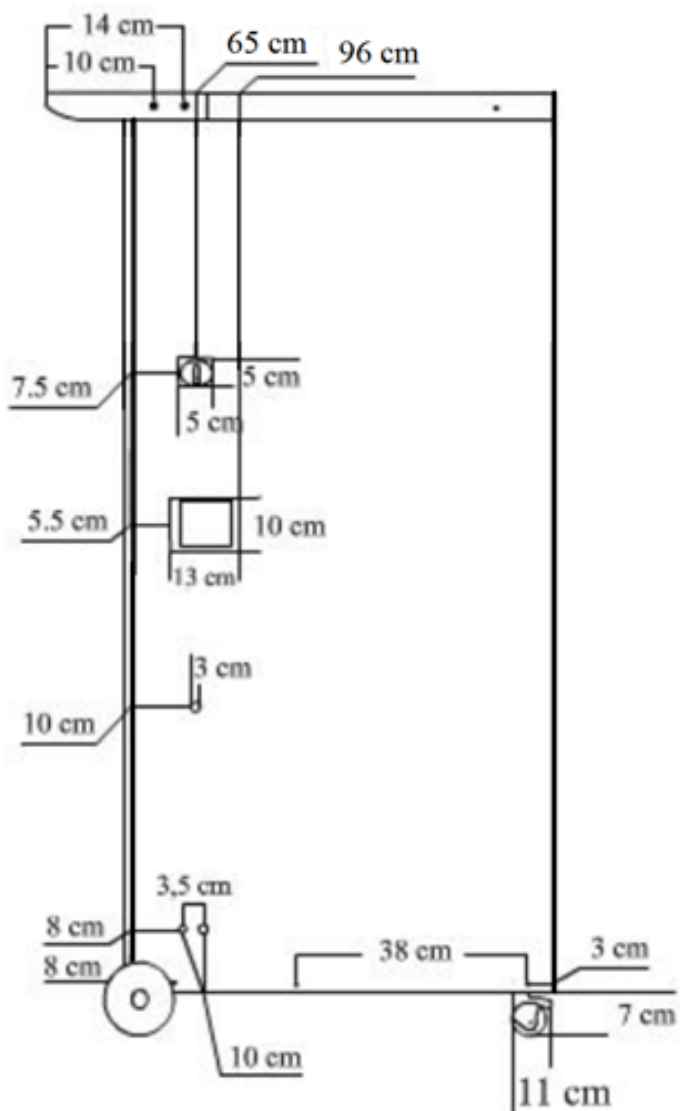

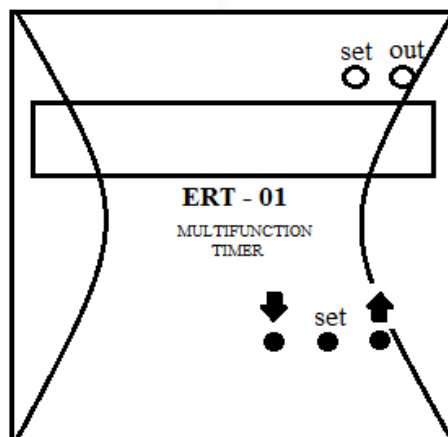
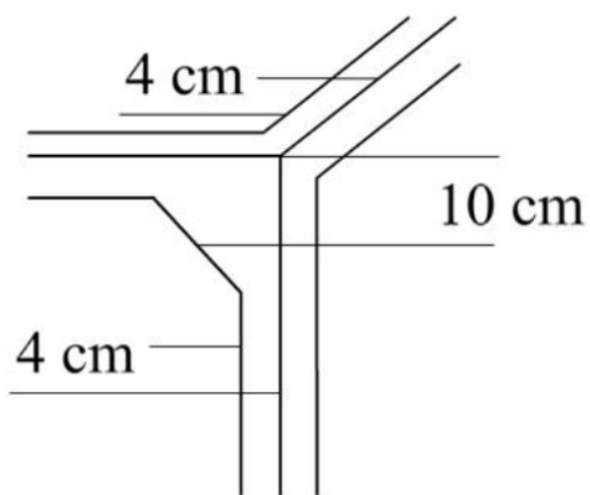
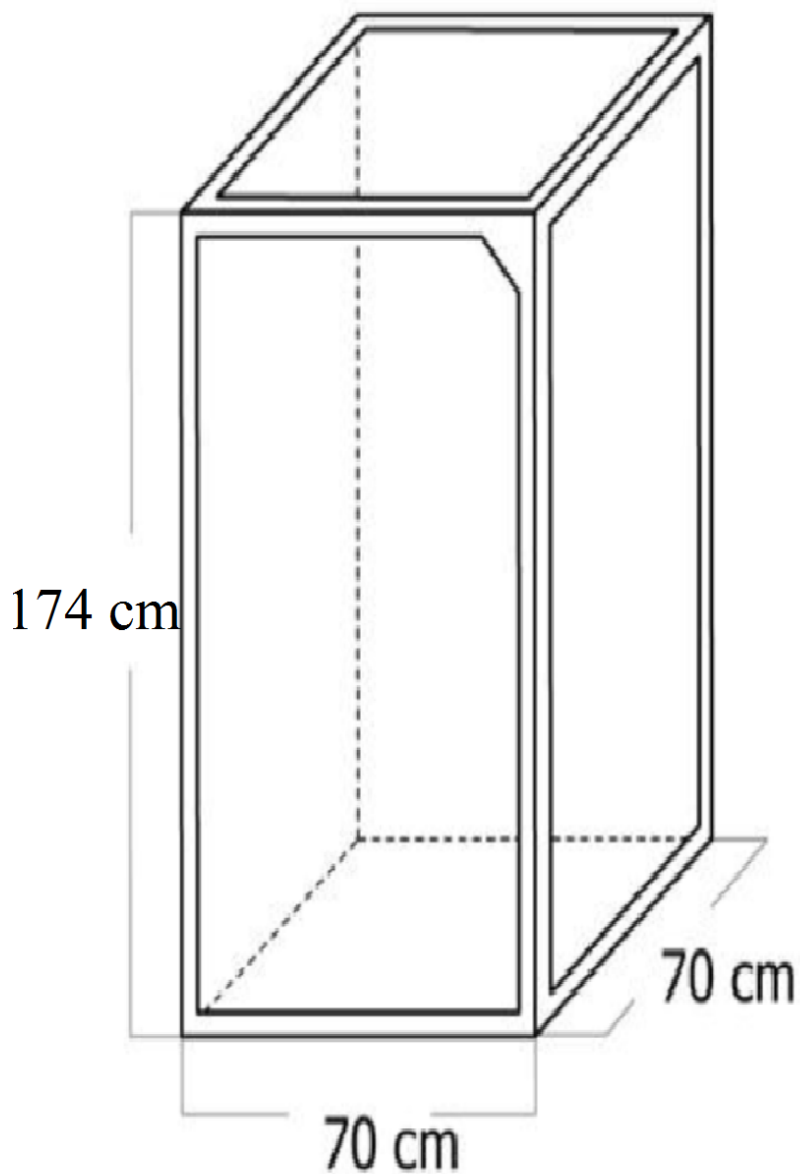

MULTIFUNCTION ELECTRONIC TIME RELAY

ERT/ERTC-01

ERT/ERTC-01 is a microcontroller controlled programmable time relay device with a wide range of time scale designed to operate in one of 4 different functions that are **On delay, Off delay, Down timer, Flasher** modes. Output relay is controlled by set value that can be set between 1.0 sec – 100 hours. Programmed function and set values are recorded at non-volatile memory. Functions and set values can be programmed easily by buttons on the front panel. ERT/ERTC-01 has optically isolated Start, Stop and Reset inputs.

Functions:

On Delay: In the On Delay mode, after the device is energized, the timer starts to count up and when it reaches the adjusted time, the relay is energized. (**dLYOn**)

Off Delay: In the Off Delay mode, after the device is energized and with start input, the relay is energized and becomes de-energized at the end of the time adjusted by the user. (**dLYOFF**)

Down Timer: In the Down Timer mode, after the device is energized, the down counter starts to count down from the time adjusted by the user and when it reaches zero, the relay is energized. (**dO Cnt**)

Flasher: In the Flasher mode, after the device is energized, when **tOFF** time ends the relay is energized and becomes de-energized at the end of the **tOn** delay (**FLSHr**). The starting mode of the flasher mode can be chosen with **StOFF** or **StOn**. In the **StOFF** mode flasher starts with **tOFF** and energized after the **tOFF** value, then continues to **tOn** mode. In the **StOn** mode flasher starts with **tOn** and deenergized after the **tOn** value, then continues to **tOFF** mode. The Flasher function is continuously repetitive.

Inputs:

Start input is used to begin counting, Stop input is used to end counting and Reset input is used to clear counter in **dLYOn, dLYOFF** and **FLSHr**. In **dO Cnt** mode reset sets the **dO Cnt** value. One of this three inputs activated by connecting them to GND.

Function Select:

The device is programmed by pressing the SET button for 3 secs. Then program menu starts with blinking of **dLYOn**. With UP and DOWN button desired mode **dLYOn, dLYOFF, dO Cnt** or **FLSHr**, and the mod led blinks. After pressing the SET button display stops blinking that this mode is chosen. Pressing once to SET button shows the old time value of this mode with blinking and this could be adjusted with UP and DOWN button. Pressing to UP or DOWN button continuous, increments or decrements the digit and still same button is pressed left digit is incremented or decremented. And this functions to left digit pressing still same button. After adjusting the time value, pressing the SET button stops the display blinking, but led button still blinks (Note that this setting operations need a few steps more for **FLSHr** mode). After pressing the SET button last time mod led stops blinking, desired mod and value are set and written to non-volatile memory.

Device can be started to counting with start input. With stop input device stops counting until stop input is deactivated. Reset input resets the time values. Device can be started with pressing set and up button at same time (same function with start input). Pressing set and down button at the same time stops counting (same function with stop input). Pressing DOWN and UP button at the same time resets counting (same function with RESET input).

PRECAUTIONS FOR INSTALLATION AND SAFE USE

Failure to follow those instructions will result in death or serious injury.

- Disconnect all power before working on equipment.
- When the device is connected to the network, do not remove the front panel.
- Do not try to clean the device with solvent or the like. Only clean the device with a dried cloth.
- Verify correct terminal connections when wiring.
- Electrical equipment should be serviced only by your compedent seller.
- No responsibility is assured by the manufacturer or any of its subsidiaries for any consequences arising out of the use of this material.
- Only for rack panel mounting.

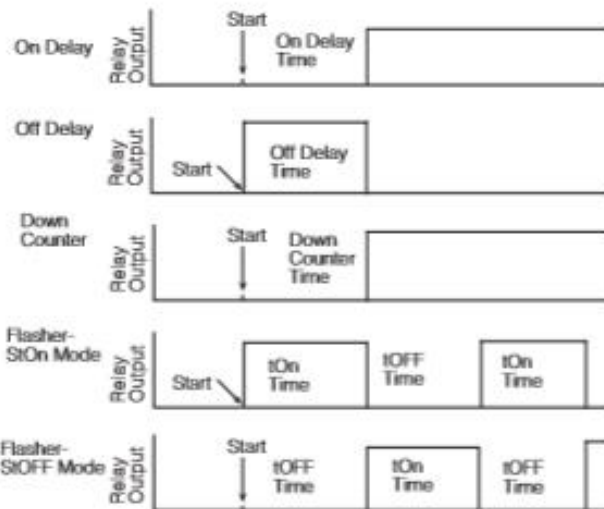

Technical Data

Operating Voltage(Un)	: 220 V AC / 120 V AC
Operating Range (AU)	: 190 - 250 V AC / 110 - 130 V AC
Operating Frequency (f)	: 50/60 Hz
Power Consumption	: < 3 VA
Output Contact	: 1 Change-Over 8A/2000VA
Error	: ±%0.5 or ±20msec. (Which is higher)
Repetition Error	: ±%0.1
Reset Time	: <= 80 msec.
Ambient Temperature	: -5°C; +50°C
Display	: Red LED display
Dimension	: PK-20 (ERTC-01) , PR-18 (ERT-01)
Equipment Protection	: Double Insulation (II)
Degree of Protection	: IP 40 (Front Panel)
	: IP 20 (Terminal Covers)
Box Material	: Nonflammable, (Yellow Certificate no:167962)
Cable Size(for terminal connection)	: 2.5 mm ²
Weight	: 0.25 kg
Installation	: Rail Mounting (ERTC-01) , Class II (ERT-01)
Package Dimensions	: 22 x 18 x 18.5 cm (ERTC-01)
	: 37 x 21.5 x 17 cm (ERT-01)
Package Weight	: 4 Kg (ERTC-01) , 4.5 Kg (ERT-01)
Pcs Per Package	: 16

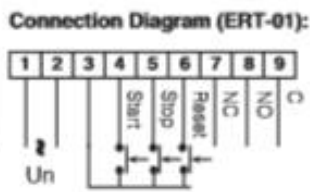
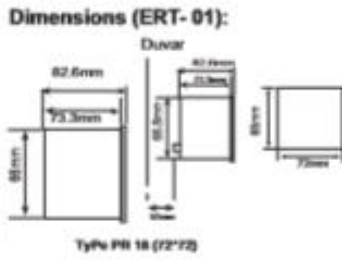
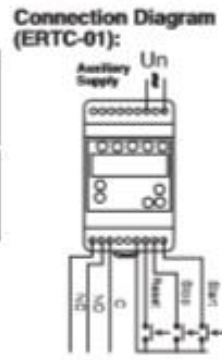
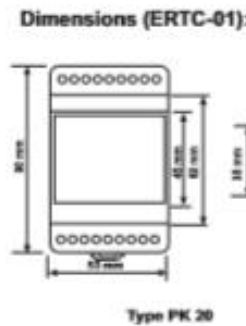
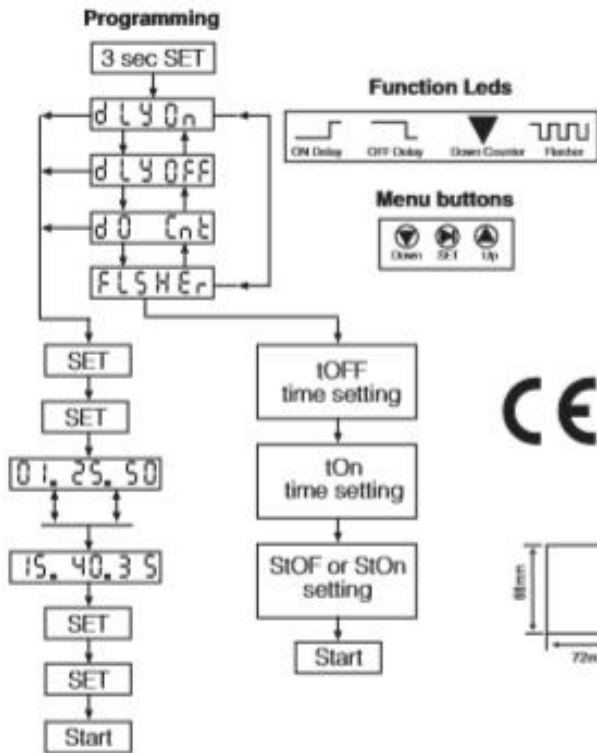

*No need of a ventilator in the installation area

XT110C - XT111C - XT110D - XT111D

Single Stage Digital Controller with Multi Probe Input



1. GENERAL WARNING

1.1 PLEASE READ BEFORE USING THIS MANUAL

- This manual is part of the product and should be kept near the instrument for easy and quick reference.
- The instrument shall not be used for purposes different from those described hereunder. It cannot be used as a safety device.
- Check the application limits before proceeding.

1.2 SAFETY PRECAUTIONS

- Check the supply voltage is correct before connecting the instrument.
- Do not expose to water or moisture: use the controller only within the operating limits avoiding sudden temperature changes with high atmospheric humidity to prevent formation of condensation
- Warning: disconnect all electrical connections before any kind of maintenance.
- The instrument must not be opened.
- In case of failure or faulty operation send the instrument back to the distributor or to "DIXELL S.p.A." (see address) with a detailed description of the fault.
- Consider the maximum current which can be applied to each relay (see Technical Data).
- Ensure that the wires for probes, loads and the power supply are separated and far enough from each other, without crossing or intertwining.
- In case of applications in industrial environments, the use of mains filters (our mod. FT1) in parallel with inductive loads could be useful.

2. GENERAL DESCRIPTION

The XT110C, XT111C and XT110D, XT111D (DIN RAIL format) are single-stage ON/OFF controllers for temperature, humidity and pressure applications with direct or inverse action, user-selectable. The analogue input type can be set by parameter between the following, according to the model:

- PTC, NTC;
- PTC, NTC, Pt100, Thermocouple J, K, S;
- 4-20mA, 0-1V, 0-10V.

3. FIRST INSTALLATION

3.1 PROBE SETTING



The pre-set probe type is written on the label of the instrument, see picture. If it is different from the probe that has been used, set the probe following procedure below

- #### 3.1.1 How to set the probe.
1. Enter the programming menu by pressing the SET+ \downarrow for 3s.
 2. Select the **Pbc (Probe configuration)** parameter and push the SET key.
 3. Set the kind of probe:
 - a. **Controller for temperature:** Pt= Pt100, J = J thermocouple, c = K thermocouple, S = S thermocouple; Ptc = PTC; ntc = ntc.
 - b. **Controller with current or voltage inputs:** cur=4-20mA, 0-1= 0-1V, 10= 0-10V
 4. Push the SET key to confirm it.
 5. Switch the controller off and on again.

NOTE: Before proceeding check and, if necessary, set with appropriate values the **Minimum Set Points (LS1 e LS2) and Maximum Set Points (US1 e US2)**. See also the paragraphs concerning the programming.

4. FRONT PANEL COMMANDS

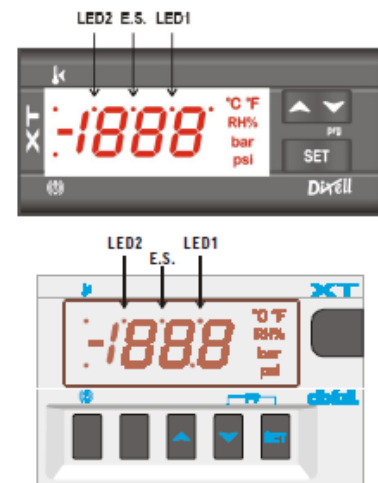

- KEY COMBINATIONS:**
- $\uparrow + \downarrow$ To lock & unlock the keyboard.
 - SET + \downarrow To enter in programming mode.
 - SET + \uparrow To return to the room temperature display.

- SET:** To display and modify target set point; in programming mode it selects a parameter or confirm an operation.
- TO SWITCH THE INSTRUMENT ON/OFF:** If the function is enabled (par. onF=yES), by pressing the SET key for more than 4s the controller is switched OFF. To switch the instrument on again press the SET key.
- **UP:** in programming mode it browses the parameter codes or increases the displayed value. Hold it pressed for a faster change
 - **DOWN:** in programming mode it browses the parameter codes or decreases the displayed value. Hold it pressed for a faster change

4.1 USE OF LEDS

A series of light points on the front panels is used to monitor the loads controlled by the instrument. Each LED function is described in the following table.

LED	MODE	FUNCTION
	ON	Output relay enabled
LED1	Flashing	- Programming Phase (flashing with LED2)
LED2	Flashing	- Programming Phase (flashing with LED1)
E.S.	ON	Energy saving activated by digital input
	ON	- ALARM signal - In "Pr2" indicates the parameter is also present in "Pr1"

4.2 TO SEE THE SETPOINT

1. Push and release the SET key to see the Set point value;
2. To come back to the normal display push again the SET key or wait 10s.

4.3 TO CHANGE THE SETPOINT

1. Hold pushed the SET key for 3s to change the Set point value;
2. The value of the set point will be displayed and the LED1 & 2 start blinking;
3. To change the Set value push the \uparrow or \downarrow arrows within 10s.
4. To memorise the new set point value push the SET key again or wait 10s.

4.4 TO ENTER THE PARAMETERS LIST "PR1"

- To enter the parameter list "Pr1" (user accessible parameters) operate as follows:
1. Push for 3s the SET + \downarrow keys (LED1 & 2 start blinking).
 2. The controller will display the first parameter present in the Pr1 menu.

4.5 TO ENTER THE PARAMETERS LIST "PR2"

- The "Pr2" parameter list contains the configuration parameters. A security code is required to enter it.
1. Enter the "Pr1" level, see above paragraph.
 2. Select "Pr2" parameter and press the "SET" key.
 3. The "PAS" flashing message is displayed, shortly followed by "0 -" with a flashing zero.
 4. Use \uparrow or \downarrow to input the security code in the flashing digit; confirm the figure by pressing "SET".
- The security code is "321".**
5. If the security code is correct the access to "Pr2" is enabled by pressing "SET" on the last digit.

Another possibility is the following:
After switching ON the instrument, within 30 seconds, push SET + \downarrow keys together for 3s: the Pr2 menu will be entered.

4.6 HOW TO MOVE A PARAMETER FROM THE "PR2" MENU TO "PR1" AND VICEVERSA.

Each parameter present in "Pr2" MENU can be removed or put into "Pr1", user level, by pressing "SET + \downarrow ". In "Pr2" when a parameter is present in "Pr1" the LED is on.

4.7 HOW TO CHANGE A PARAMETER

- To change a parameter value operates as follows:
1. Enter the **Programming mode**
 2. Select the required parameter.
 3. Press the "SET" key to display its value.
 4. Use "UP" or "DOWN" to change its value.
 5. Press "SET" to store the new value and move to the following parameter.

TO EXIT: Press SET + UP or wait 15s without pressing a key.
NOTE: the set value is stored even when the procedure is exited by waiting the time-out to expire.

4.8 HOW TO LOCK THE KEYBOARD

- 
1. Keep pressed for more than 3 s the \uparrow and \downarrow keys.
 2. The "POF" message will be displayed and the keyboard will be locked. At this point it will be possible only to see the set point or the MAX o Min temperature stored
 3. If a key is pressed more than 3s the "POF" message will be displayed.

4.9 TO UNLOCK THE KEYBOARD

Keep pressed together for more than 3s the \uparrow and \downarrow keys, till the "Pon" message will be displayed.

4.10 ON/OFF FUNCTION

TO SWITCH THE INSTRUMENT ON/OFF: If the function is enabled (par. onF=yES), by pressing the SET key for more than 4s the controller is switched OFF. To switch the instrument on again press the SET key.

5. PROBES AND MEASURING RANGE

Probe	Down Scale	Full Scale
NTC	-40°C / -40°F	110°C / 230 °F
PTC	-50°C / -58°F	150°C / 302°F
Pt100	-200°C / -328°F	600°C / 1112°F
TcK	0°C / 32°F	1300°C / 1999°F
TcJ	0°C / 32°F	600°C / 1112°F
TcS	0°C / 32°F	1400°C / 1999°F

15. DEFAULT SETTING VALUES				
COd	Name	Range	°C/F	Lev
Set	Set point	LS1- US1	0/32	-
Hy1	Differential	-Full Sc./ Full Sc.	-1/-2	Pr1
LS1	Minimum set point	Down Sc./ Set	min	Pr2
US1	Maximum set point	Set/ Full Sc.	max	Pr2
StC	Action type output	in- Inverse; dir-direct	in	Pr2
Ac	Anti-short cycle delay;	0- 250 sec	0	Pr2
on	Minimum time a stage stays switched ON	0- 250 sec	0	Pr2
ono	Minimum time between 2 following switching ON of the same load	0- 120 min	0	Pr2
ALC	Alarm configuration	rE-relat.; Ab- absolute	rE	Pr2
ALL	Minimum alarm (ALC-rE) (ALC-Ab)	0 + Start Sc.-Set Start Sc.- ALu	10.0/ 20	Pr2
ALU	Maximum alarm (ALC-rE) (ALC-Ab)	0 + Full Sc.-Set . ALL- Full Scale	10.0/ 20	Pr2
ALH	Alarm recovery differential	0- Full scale	2.0/4	Pr2
ALd	Alarm delay	0- 999 min	15	Pr2
adao	Alarm delay at start up	0- 23h 50min	1.3	Pr2
So1	Output status with faulty pr.	oFF-open on-closed	oFF	Pr2
AbA ¹	Alarm relay disabling	no; yES	yES	Pr2
AS ¹	Alarm relay polarity	CL-oP	oP	Pr2
Lc ²	Start scale with current or voltage input	-1999- 1999	various	Pr1
Uc ²	End scale with current or voltage input	-1999- 1999	various	Pr1
OPb	Probe calibration	-Full Sc./ Full Sc.	0.0	Pr1
yES	Resolution	in-NO; dE-0.1; cE-0.01	in	Pr2
UdM	Measurement unit (temp.) (current/voltage)	°C-°C; °F- °F; 0-°C; 1-°F; 2-RH; 3-bar; 4-PSI; 5-off	various	Pr1
PbC	Kind of probe	Pt-Pt100; J-tc.; c- tck; S-tcS; Pt-PTC; ntc- NTC; 0-1-0- 1V; 10- 0- 10V; cur-0- 20mA	various	Pr1
P3F	3 rd wire presence	no-2 wires; yES-3 wires	no	Pr2
Aoc ³	Analog output setting	Pb / Er	Pb	Pr2
LAo ³	Lower analog output limit:	Down Sc./ Full Sc.	0	Pr2
uAo ³	Upper analog output limit:	Down Sc./ Full Sc.	0	Pr2
SAo ³	Analog output safety with probe fault	oFF / on	oFF	Pr2
HES	Energy saving differential	Down Sc./ Full Sc.	0.0	Pr2
i1F	Digital input configuration	c-H / oFF / AuS / HES / EAL / bAL	EAL	Pr2
i1P	Digital input polarity	cL-closed; oP-open	cL	Pr2
did	Alarm delay for dig. input	0- 120m	0	Pr2
Adr	Serial address	0- 247	1	Pr2
Onf	oFF function enabling	no-not enabled; yES-enabled	no	Pr2
Ptb	Parameter table	Readable only	--	Pr2
yEL	Software release	Readable only	--	Pr2
Pr2	To access the Pr2	Readable only	321	Pr1

¹ Only for XT111C/XT111D;² Only for instrument with 4- 20mA or 0- 1V or 0- 10V;³ Only for instruments with analog output

ENGLISH

1 GETTING STARTED

1.1 Important

Read these Instructions carefully before installing and using the Instrument and follow all additional information for installation and electrical connection; keep these instructions close to the Instrument for future consultations.

1.2 Installing the Instrument

Panel mounting, with click brackets (supplied by the builder); dimensions in mm (in).

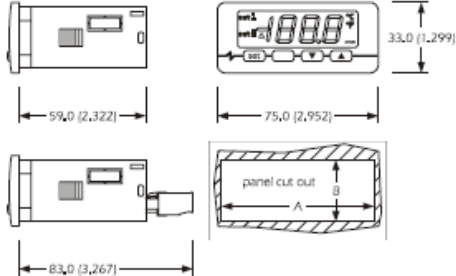

Additional Information for Installation:

- 59.0 (2.322) is the maximum depth with screw terminal blocks
- 83.0 (3.267) is the maximum depth with extractable terminal blocks
- the panel thickness must not be higher than 8.0 mm (0.314 in)
- working conditions (working temperature, humidity, etc.) must be between the limits indicated in the technical data
- do not install the Instrument close to heating sources (heaters, hot air ducts, etc.), devices provided with big magnetos (big speakers, etc.), locations subject to direct sunlight, rain, humidity, dust, mechanical vibrations or bumps
- according to the safety legislation, the protection against electrical parts must be ensured by a correct installation of the Instrument; the parts that ensure the protection must be installed so that you can not remove them if not by using a tool.

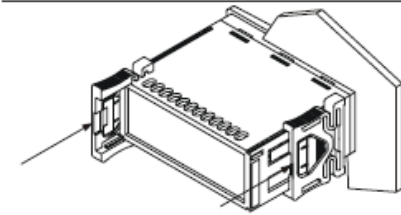

1.3 Wiring diagram
With reference to the wiring diagram:

- the serial port (by request) is the port for the communication with the supervision system (through a serial interface, via TTL, with MODBUS communication protocol) or with the programming key; the port must not be used at the same time for the same purposes.

Additional Information for electrical connection:

- do not operate on the terminal blocks with electrical or pneumatic screwdrivers
- if the Instrument has been moved from a cold location to a warm one, the humidity could condense on the inside; wait about an hour before supplying it

Additional Information for electrical connection:

- do not operate on the terminal blocks with electrical or pneumatic screwdrivers
- if the Instrument has been moved from a cold location to a warm one, the humidity could condense on the inside; wait about an hour before supplying it

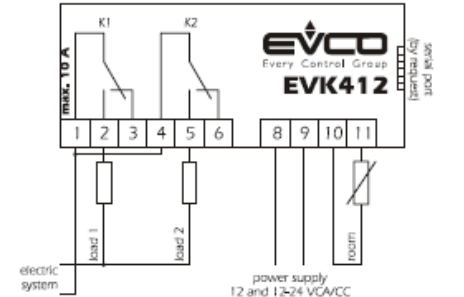
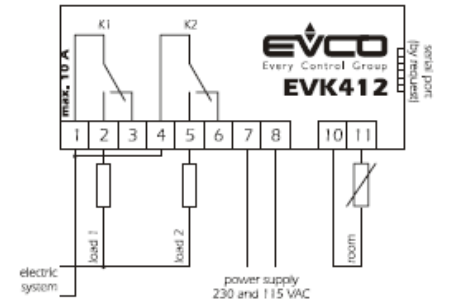

Additional Information for electrical connection:

- do not operate on the terminal blocks with electrical or pneumatic screwdrivers
- if the Instrument has been moved from a cold location to a warm one, the humidity could condense on the inside; wait about an hour before supplying it

- test the working power supply voltage, working electrical frequency and working electrical power of the Instrument; they must correspond with the local power supply
- disconnect the local power supply before servicing the Instrument
- do not use the Instrument as safety device
- for repairs and information on the Instrument please contact Evco sales network.

2 USER INTERFACE

2.1 Turning on/off the instrument

To turn on the instrument you have to supply it; to turn it off it is enough to cut off the power supply.

2.2 The display

If the Instrument is turned on, during the normal operation the display will show the quantity you have set with parameter P5:

- if P5 = 0, the display will show the room temperature
- if P5 = 1, the display will show the first working setpoint.

2.3 Showing the room temperature

- make sure the keyboard is not locked and no procedure is running
- press **set** 2 s: the display will show "Pb1"
- press **set**
- press **set** or do not operate 60 s
- press **▲** or **▼** as long as the display shows the quantity you have set with parameter P5 or do not operate 60 s.

2.4 Locking/unlocking the keyboard

- To lock the keyboard:
- make sure no procedure is running
 - press **set** and **▼** 2 s: the display will show "Loc" 1 s.
- If the keyboard is locked, you will not be allowed to:
- modify the working setpoints with the procedures related in paragraphs 4.1 and 4.2 (you also can modify the working setpoints through parameters SP1 and SP2).
- This operation provokes the visualization of the label "Loc" 1 s.

To unlock the keyboard:

- press **set** and **▼** 2 s: the display will show "UnL" 1 s.

2.5 Silencing the buzzer

- make sure no procedure is running
- press a button (the first pressure of the button does not provoke its usual effect).

3 OPERATION

3.1 Preliminary Information

The operation mainly depends on parameter CFG.

3.2 Operation with parameter CFG = 1 (the first working setpoint is independent and the second one is relative to the first)

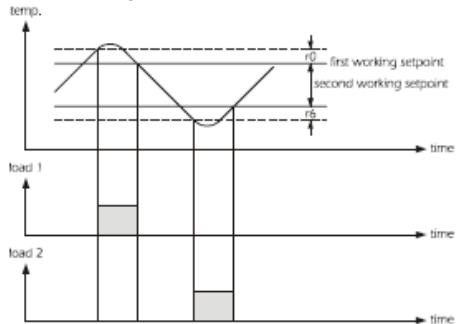

If parameter CFG has value 1, you can set the second working setpoint through parameter SP2 only (because it is relative to the first one). You can get each load to work for cooling (parameters r5 and r10 = 0) or for heating (parameters r5 and r10 = 1). In this example load 1 works for cooling, load 2 works for heating and the second working setpoint has a negative value.

3.3 Operation with parameter CFG = 2 (two independent working setpoints)

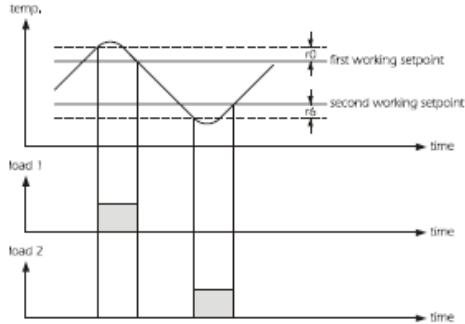

If parameter CFG has value 2, you can get each load to work for cooling (parameters r5 and r10 = 0) or for heating (parameters r5 and r10 = 1). In this example load 1 works for cooling and load 2 works for heating.

3.4 Operation with parameter CFG = 3 (neutral zone)

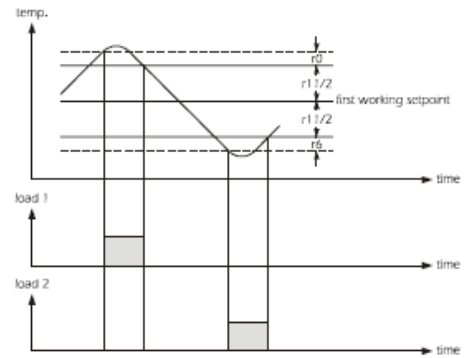

If parameter CFG has value 3, the second working setpoint will not be available and parameters SP2, r5, r7, r8, r9 and r10 will not be significant.

Load 1 always works for cooling and load 2 always works for heating.

3.5 Operation with parameter CFG = 4 (two steps)

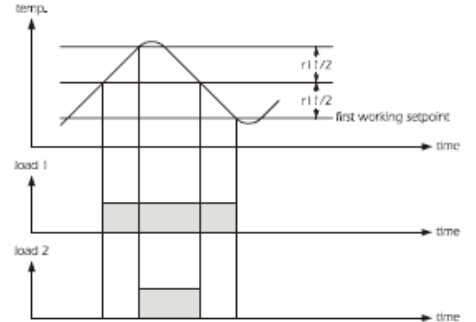

If parameter CFG has value 4, the second working setpoint will not be available and parameters SP2, r0, r6, r7, r8, r9 and r10 will not be significant.

You can get each load to work for cooling (parameter r5 = 0) or for heating (parameter r5 = 1); parameter r5 sets the action for each load. In this example each load works for cooling.

4 SETTINGS

4.1 Setting the first working setpoint

- make sure the keyboard is not locked and no procedure is running
- press **set** LED out 1 will flash
- press **▲** or **▼** in 15 s; also look at parameters r1, r2 and r3
- do not operate 15 s.

You also can modify the first working setpoint through parameter SP1.

4.2 Setting the second working setpoint

- press **set** during the modification of the first working setpoint: LED out 2 will flash
- press **▲** or **▼** in 15 s; also look at parameters r7, r8 and r9
- press **set** or do not operate 15 s.

You also can modify the second working setpoint through parameter SP2.

If parameter CFG has value 1, you can set the second working setpoint through parameter SP2 only (because it is relative to the first one).

If parameter CFG has value 3 or 4, the second working setpoint will not be available.

4.3 Setting configuration parameters

To gain access the procedure:

- make sure no procedure is running
- press **▲** and **▼** 4 s: the display will show "PA"
- press **set**
- press **▲** or **▼** in 15 s to set "19"
- press **set** or do not operate 15 s
- press **▲** and **▼** 4 s: the display will show "SP1"

To select a parameter:

- press **▲** or **▼**
- To modify a parameter:
- press **set**
- press **▲** or **▼** in 15
- press **set** or do not operate 15 s

To quit the procedure:

- press **▲** and **▼** 4 s; or do not operate 60 s.

Switch off/on the power supply of the Instrument after the modification of the parameters.

4.4 Restoring the default value of configuration parameters

- make sure no procedure is running
- press **▲** and **▼** 4 s: the display will show "PA"
- press **set**
- press **▲** or **▼** in 15 s to set "743"
- press **set** or do not operate 15 s
- press **▲** and **▼** 4 s: the display will show "DEF"
- press **set**
- press **▲** or **▼** in 15 s to set "149"

- press **set** or do not operate 15 s: the display will show "DEF" flashing 4 s, after which the instrument will quit the procedure
- switch off/on the power supply of the instrument.

Make sure the default value of the parameters is appropriate. In particular if the probes are NTC probes.

5 SIGNALS

5.1 Signals

LED	MEANING
out 1	LED load 1 If it is lit, load 1 will be turned on If it flashes: • the modification of the first working setpoint will be running • a load 1 protection will be running (parameters C1 and C2)
out 2	LED load 2 If it is lit, load 2 will be turned on If it flashes: • the modification of the second working setpoint will be running • a load 2 protection will be running (parameters C7 and C8)
	LED alarm If it is lit, an alarm will be running
°C	LED Celsius degree If it is lit, the unit of measure of the temperatures will be Celsius degree (parameter P2)
°F	LED Fahrenheit degree If it is lit, the unit of measure of the temperatures will be Fahrenheit degree (parameter P2)
CODE	MEANING
Loc	the keyboard and/or the working setpoints are locked (parameter r3 and/or r9); also look at paragraph 2.4

6 ALARMS

6.1 Alarms

CODE	MEANING
AL1	First temperature alarm Remedies: • check the room temperature • look at parameters A1 and A3 Effects: • no effect
AL2	Second temperature alarm Remedies: • check the room temperature • look at parameters A5 and A7 Effects: • no effect

When the cause that has provoked the alarm disappears, the instrument restores the normal operation.

7 INTERNAL DIAGNOSTICS

7.1 Internal diagnostics

CODE	MEANING
Pr1	Room probe error Remedies: • look at parameter P0 • check the integrity of the probe • check the connection Instrument-probe • check the room temperature Effects: • load 1 activity will depend on parameter C6 • load 2 activity will depend on parameter C10

When the cause that has provoked the alarm disappears, the instrument restores the normal operation.

8 TECHNICAL DATA

8.1 Technical data

Box: self-extinguishing grey.

Frontal protection: IP 65.

Connections: screw terminal blocks (power supply, input and outputs), 6 poles connector (serial port; by request); extractable terminal blocks (power supply, input and outputs) by request.

Working temperature: from 0 to 55 °C (32 to 131 °F, 10 ... 90% of relative humidity without condensate).

Power supply: 230 VAC, 50/60 Hz, 3 VA (approximate); 115 VAC or 12-24 VAC/DC or 12 VAC/DC by request.

Alarm buzzer: by request.

Measure inputs: 1 (room probe) for PTC/NTC probes.

Working range: from -50.0 to 150.0 °C (-50 to 300 °F) for PTC probe, from -40.0 to 105.0 °C (-40 to 220 °F) for NTC probe.

Resolution: 0.1 °C/1 °C/1 °F

Digital outputs: 2 relays:

- **load 1 relay:** 16 res. A @ 250 VAC (change-over contact).
- **load 2 relay:** 8 res. A @ 250 VAC (change-over contact).

The maximum current allowed on the loads is 10 A.

Serial port: port for the communication with the supervision system (through a serial interface, via TTL, with MODBUS communication protocol) or with the programming key; by request.

ENGLISH

9 WORKING SETPOINTS AND CONFIGURATION PARAMETERS

9.1 Working setpoints

	MIN.	MAX.	U.M.	DEF.	WORKING SETPOINTS
r1	r2		°C/°F (1)	0.0	first working setpoint
r7	r8		°C/°F (1)	0.0	second working setpoint

9.2 Configuration parameters

PARAM.	MIN.	MAX.	U.M.	DEF.	WORKING SETPOINTS
SP1	r1	r2	°C/°F (1)	0.0	first working setpoint
SP2	r7	r8	°C/°F (1)	0.0	second working setpoint
PARAM.	MIN.	MAX.	U.M.	DEF.	MEASURE INPUTS
CA1	-25.0	25.0	°C/°F (1)	0.0	room probe offset
P0	0	1	---	0	kind of probe 0 = PTC 1 = NTC
P1	0	1	---	1	decimal point Celsius degree (for the quantity to show during the normal operation) 1 = YES
P2	0	1	---	0	unit of measure temperature (2) 0 = °C 1 = °F
P5	0	1	---	0	quantity to show during the normal operation 0 = room temperature 1 = first working setpoint

PARAM.	MIN.	MAX.	U.M.	DEF.	REGULATORS
A2	0	240	min	0	first temperature alarm delay
A3	0	4	---	0	kind of first temperature alarm 0 = alarm not enabled 1 = absolute lower alarm (or A1) 2 = absolute upper alarm (or A1) 3 = lower alarm relative to the first working setpoint (or "first working setpoint - A1"; consider A1 without sign) 4 = upper alarm relative to the first working setpoint (or "first working setpoint + A1"; consider A1 without sign)
A4	0	240	min	0	temperature alarms delay since an independent working setpoint modification
A5	-99.0	(3)	°C/°F (1)	0.0	temperature the second temperature alarm is activated; also look at A7 (5)
A6	0	240	min	0	second temperature alarm delay
A7	0	4	---	0	kind of second temperature alarm 0 = alarm not enabled 1 = absolute lower alarm (or A5) 2 = absolute upper alarm (or A5) 3 = lower alarm relative to the second working setpoint (or "second working setpoint - A5"; consider A5 without sign) (6) 4 = upper alarm relative to the second working setpoint (or "second working setpoint + A5"; consider A5 without sign) (6)

PARAM.	MIN.	MAX.	U.M.	DEF.	SERIAL NETWORK (MODBUS)
LA	1	247	---	247	instrument address
Lb	0	3	---	2	baud rate 0 = 2,400 baud 1 = 4,800 baud 2 = 9,600 baud 3 = 19,200 baud
LP	0	2	---	2	parity 0 = none 1 = odd 2 = even

PARAM.	MIN.	MAX.	U.M.	DEF.	RESERVED
E9	0	1	---	1	reserved

PARAM.	MIN.	MAX.	U.M.	DEF.	OPERATION
CFG	1	4	---	1	operation 1 = the first working setpoint is independent and the second one is relative to the first 2 = two independent working setpoints 3 = neutral zone 4 = two steps

- (1) the unit of measure depends on parameter P2
(2) **set the parameters related to the regulators appropriately after the modification of the parameter P2**
(3) the value depends on parameter P2 (150.0 °C or 300 °F)
(4) if the parameter has value 0, the delay since the end of the room probe error will however be 2 min
(5) the differential of the parameter is 2.0 °C/4 °F
(6) if parameter CFG has value 1, 3 or 4, the second temperature alarm will be relative to the first working setpoint (because the first working setpoint is relative to the first or it is not available).

 The instrument must be disposed according to the local legislation about the collection for electrical and electronic equipment.
Lo strumento deve essere smaltito secondo le normative locali in materia di raccolta delle apparecchiature elettriche ed elettroniche.

ITALIANO

9 SETPOINT DI LAVORO E PARAMETRI DI CONFIGURAZIONE

9.1 Setpoint di lavoro

	MIN.	MAX.	U.M.	DEF.	SETPOINT DI LAVORO
r1	r2		°C/°F (1)	0.0	primo setpoint di lavoro
r7	r8		°C/°F (1)	0.0	secondo setpoint di lavoro

9.2 Parametri di configurazione

PARAM.	MIN.	MAX.	U.M.	DEF.	SETPOINT DI LAVORO
SP1	r1	r2	°C/°F (1)	0.0	primo setpoint di lavoro
SP2	r7	r8	°C/°F (1)	0.0	secondo setpoint di lavoro
PARAM.	MIN.	MAX.	U.M.	DEF.	INGRESSI DI MISURA
CA1	-25.0	25.0	°C/°F (1)	0.0	offset sonda ambiente
P0	0	1	---	0	tipo di sonda 0 = PTC 1 = NTC
P1	0	1	---	1	punto decimale grado Celsius (per la grandezza visualizzata durante il normale funzionamento) 1 = SI
P2	0	1	---	0	unità di misura temperatura (2) 0 = °C 1 = °F
P5	0	1	---	0	grandezza visualizzata durante il normale funzionamento 0 = temperatura dell'ambiente 1 = primo setpoint di lavoro

REGOLATORI

PARAM.	MIN.	MAX.	U.M.	DEF.	REGOLATORI
A2	0	240	min	0	ritardo primo allarme di temperatura
A3	0	4	---	0	tipo di primo allarme di temperatura 0 = allarme assente 1 = di minima assoluto (ovvero A1) 2 = di massima assoluto (ovvero A1) 3 = di minima relativo al primo setpoint di lavoro (ovvero "primo setpoint di lavoro - A1"; considerare A1 senza segno) 4 = di massima relativo al primo setpoint di lavoro (ovvero "primo setpoint di lavoro + A1"; considerare A1 senza segno)
A4	0	240	min	0	ritardo allarmi di temperatura dalla modifica di un setpoint di lavoro indipendente
A5	-99.0	(3)	°C/°F (1)	0.0	temperatura alla quale viene attivato il secondo allarme di temperatura; si veda anche A7 (5)
A6	0	240	min	0	ritardo secondo allarme di temperatura
A7	0	4	---	0	tipo di secondo allarme di temperatura 0 = allarme assente 1 = di minima assoluto (ovvero A5) 2 = di massima assoluto (ovvero A5) 3 = di minima relativo al secondo setpoint di lavoro (ovvero "secondo setpoint di lavoro - A5"; considerare A5 senza segno) (6) 4 = di massima relativo al secondo setpoint di lavoro (ovvero "secondo setpoint di lavoro + A5"; considerare A5 senza segno) (6)

PARAM.	MIN.	MAX.	U.M.	DEF.	RETE SERIALE (MODBUS)
LA	1	247	---	247	Indirizzo strumento
Lb	0	3	---	2	baud rate 0 = 2,400 baud 1 = 4,800 baud 2 = 9,600 baud 3 = 19,200 baud
LP	0	2	---	2	parità 0 = nessuna parità 1 = dispari 2 = pari

PARAM.	MIN.	MAX.	U.M.	DEF.	RISERVATO
E9	0	1	---	1	riservato

PARAM.	MIN.	MAX.	U.M.	DEF.	FUZIONAMENTO
CFG	1	4	---	1	funzionamento 1 = il primo setpoint di lavoro è indipendente e il secondo è relativo al primo 2 = due setpoint di lavoro indipendenti 3 = zona neutra 4 = due gradini

- (1) l'unità di misura dipende dal parametro P2
(2) **impostare opportunamente i parametri relativi ai regolatori dopo la modifica del parametro P2**
(3) il valore dipende dal parametro P2 (150.0 °C o 300 °F)
(4) se il parametro è impostato a 0, il ritardo dalla conclusione dell'errore sonda ambiente sarà comunque di 2 min
(5) il differenziale del parametro è di 2.0 °C/4 °F
(6) se il parametro CFG è impostato a 1, 3 o 4, il secondo allarme di temperatura sarà relativo al primo setpoint di lavoro (perché il secondo setpoint di lavoro è relativo al primo o non è disponibile).

